

Operation and maintenance instructions

First edition

instructions

**Original
instructions**



R18-4

HYDRAULIC EXCAVATOR

Warning:Unsafe use of this machine may cause serious injury or death.Operation and maintenance personnel must read this manual before operating and maintaining this machine.This manual should be placed near the machine for timely reference and all personnel related with this machine should consult this manual regularly.

Name:Shandong Rippa Machinery Group Co.,Ltd.

Address:No.6 industrial Park,No.2166 Chongwen Avenue,High Tech Zone,Jining City,Shandong Province,P.R.Chine

R18-4

Operation and maintenance description of hydraulic excavator

Warning: Unsafe use of this machine may cause serious injury or death. Operation and maintenance personnel must read this manual before operating and maintaining this machine. This manual shall be placed near the machine for timely access and all machine-related personnel.

Shandong Rippa Machinery Group Co., Ltd
No.6 Industrial Park, No.2166, Chongwen Avenue, High-tech Zone, Jining
City, Shandong Province

preface

Dear user,

Thank you for your trust and love for our products! The company production product series is mining, lifting, and unloading operations giving priority to, agricultural as complementary small excavator, our product design structure is compact, dynamic matching, good product stability, cost-effective, and can meet the plains, hills, forests under the condition of mining unloading requirements, also applies to brick factory, kiln, river, construction, dredging, road construction. It can reduce the worker's physical labor, speed up the construction progress, and improve the level of mechanization.

In order to help the user master the knowledge of the machine's use, adjustment, and maintenance and give full play to the excavator's use effect, please read and implement the provisions in this operation and maintenance manual carefully. For the use and maintenance of the supporting engine, please refer to the Engine Operation Manual prepared by the supporting engine plant.

Operation part: The driver uses the technical reference of the machine, during which the driver can instruct the driver to use the correct procedure to check, start, operate, and stop the machine. The operating techniques outlined in the manual are a foundation on which the driver learns about the machine and its functions to improve his skills.

Maintenance part: the user's maintenance instructions for the whole machine. The specific maintenance measures of the machine are detailed in the "Excavator Maintenance Catalogue". Users shall maintain the repair items according to the requirements and different mechanical working hours.

Depending on the number of machines under extremely harsh, dusty, or wet working conditions.

Part of the demonstration pictures in this manual are set to a structural perspective view to more intuitively show some structural features of the machine, so their appearance will be different from the actual product. If the excavator's actual mechanical structure and technical parameters change due to technical improvement but are not listed in this manual, please consult the company for the latest product information.

Before the machine can be used or repaired, the relevant information must be approved, and the company's technical service station can be contacted if necessary. When purchasing accessories, please indicate the factory date and number of the excavator.

To facilitate your use, the company has established a perfect "three guarantees of technical service network". If during the warranty period, you buy our small agricultural excavator under the correct use of quality problems, please contact the local excavator's three insurance maintenance service stations.

Due to the continuous innovation of product technology, this manual reserves the right to interpret and modify.

If the actual product does not match with pictures in this manual, the physical object shall prevail.

Warn! This machine shall not be used for the following purposes:

- Lifting operation;
- Lifting operation (additional protection should be installed);
- Disassembly (if used as a disassembly machine, a protective device shall be installed);
- Areas at risk of falling objects (no top guard or FOPS installed)
- Unhealthy areas, such as contaminated areas;
- Lightning climate.

catalog

Chapter 1: Safety precautions and safety identification	8
1.1 Safety Precautions	8
1.2 Safety Identification Tips	8
1.3 Location of Safety Identification	9
1.4 Nameplate sign	13
1.5 Safety information	14
Chapter 2: Preparation before the Work	23
2.1 Fuel Volume Inspection	23
2.2 Track tension inspection	23
2.3 Hydraulic oil and oil quantity inspection	24
2.4 Check the lubrication point	25
2.5 Check the tightness of the fixing bolts for important parts	25
2.6 Oil Leakage Inspection	26
2.7 Check the operation area	26
2.8 Check the strength of the bridge	27
2.9 Always keep the machine clean	27
2.10 Routine inspection and maintenance	27
2.11 Use of the Bucket	27
Chapter 3: The Safe Operation of the Machine	29
3.1 Start the engine	29
3.2 Preparation before Startup	29
3.3 Operation	31
3.4 Setting of the Workstation	31
3.5 Check the rearview mirror	32
3.6 Description of the display and operation unit	32
3.7 Other equipment in the driver's seat	33
3.8 Overview of control lever functions (default setting)	34
3.9 Ceiling	36

3.10 Rotational safety precautions	37
3.11 Safety precautions for travel	38
3.12 Walking on the slope	39
3.13 Operation on the slope	40
3.14, prohibit operation	40
3.15, snow day work	42
3.16 Parking	42
3.17 Transportation	42
3.18 Installation and unloading of the machines	43
3.19, and the transport machine	43
3.20 Bucket lifting operation	44
Chapter 4: Basic parameters of the excavator	46
4.1 Basic Parameters	46
4.2 Hinge connecting pin of the machine working device	47
4.3 Main Dimensions and Specifications	48
4.4 Hydraulic schematic diagram and detailed information	49
4.5 Electrical schematic diagram and details	49
4.6 Excavator parameter Table	52
Chapter 5: Common faults and solutions	54
5.1 Common faults and solutions of excavator	54
5.2 Clean the overflow valve (safety valve) and adjust the system pressure	57
5.3 Install a single track	57
Chapter 6: Maintenance and Maintenance	59
6.1 Notes for maintenance	59
6.2 Fuel oil recommendation	61
6.3 Description of the machine lubrication parts	62
6.4 Maintenance Directory	63
6.5 Replace the engine oil	65
6.6 Method of replacing the filter element	66
The EC qualification declaration	68

List of accessories and spare parts 69

Chapter 1 Safety precautions and safety identification

1.1 Safety precautions

General preventive measures

Observe safety regulations and laws and operate, inspect, and maintain the machine as required by the manufacturer.

1.2 Safety Identification Tips

Use the following warning signs and safety signs.

1. Be sure to fully understand the correct location and content of the logo.
2. To ensure that the identification is visible, ensure that the identification position is correct and keep it clean. When cleaning the label, do not use organic solvents or gasoline, otherwise it will peel off.
3. Besides warning signs and safety signs, there are other signs treated in the same way.
4. If the identification is damaged, lost, or invisible, replace it. Please refer to this manual or actual identification and send the order to the factory.

1.3 Location of safety identification

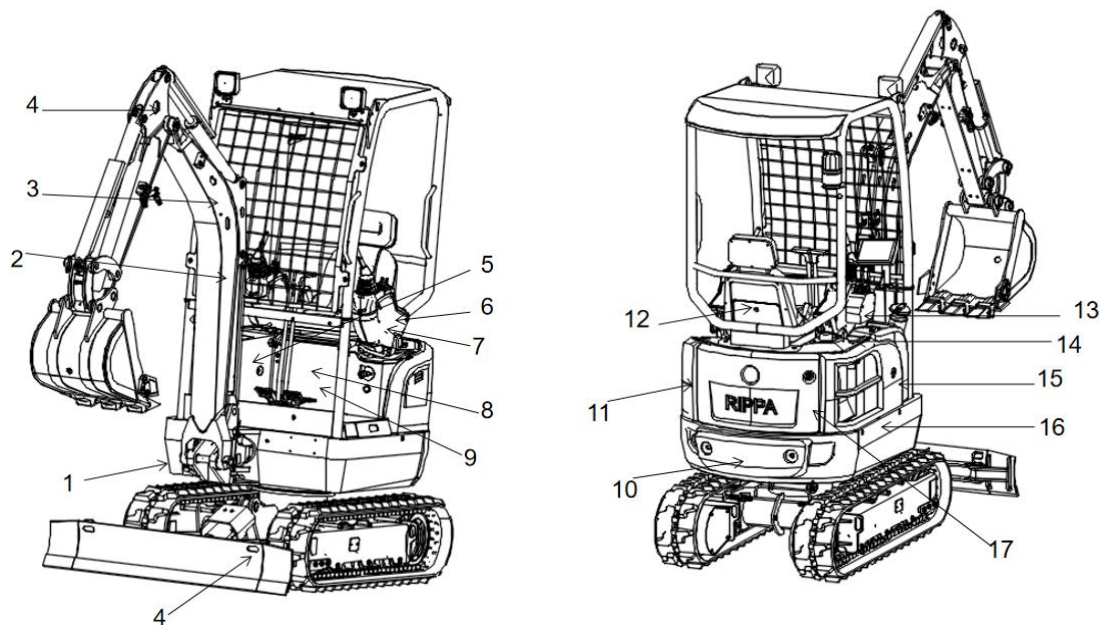

(1) Pay attention to the machine running noise of 93dB

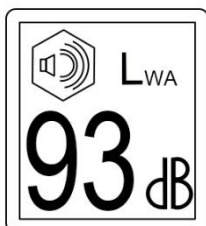

△ Warning: Under certain specific operating conditions of the machine, the actual noise value may be different from that determined using the noise test code.

The measured A-weighted emission acoustic power is 92 dB (A).

The guaranteed sound power is 93 dB (A).

The uncertainty of the noise emission value is 3.5 dB.

(2) No one shall stand at the lower end of the working device



△ Never stand in the machine working device area.

△ Do not damage or remove the marks on the machine.

(3) Brand models



(4) Hoisting position

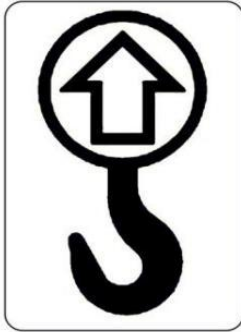

(5) Schematic diagram of the excavator operation mode

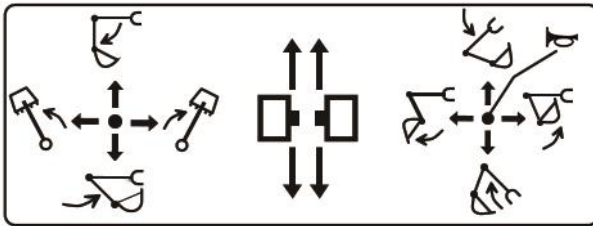

△ Conduct the basic operation of the excavator according to the figure above. Operate the excavator strictly by mark.

(6) Wear the ear guard device when operating the excavator



△ With an ear protection device warning

(7) After operating the machine, put down the operation lock



△ This identification is the operating locking mechanism. After operating the machine,

lower the lock lever to avoid the driver.

(8) Excavator excavation parameters

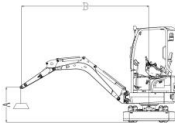
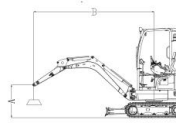
Lift capacity ratings										
										
A: Load radius	Conditions of operation									
B: Load point height	940mm Big arm									
C: Lift capacity ratings	1780mm ARm									
Cf: Rated loads over front	weight: 1818kg									
Cs: Rated loads	Track width: 230mm									
(Unit: kg)	Track spacing: 840mm									
Load point height (Unit: mm)	Load radius A (Static-bulldozer support)									
	1.5		2		2.5		Max			
	Cf	Cs	Cf	Cs	Cf	Cs	Cf	Cs	A (mm)	
1.5	565	628	407	383	388	304	330	222	3201	
1	686	647	521	388	449	298	334	220	3300	
0.5	804	571	635	394	454	286	339	218	3376	
0 (Grade)	934	616	683	438	481	301	423	230	3317	
-1	948	635	583	453	508	323	438	258	2862	
-1.1	962	704	538	464	525	340	454	274	2784	

(9) Maintenance labels

MAINTENANCE PRECAUTIONS
 VORSICHTSMAßNAHMEN FÜR DIE WARTUNG



- Pin, buttering is recommended every 10 hours
Stift, Buttering wird alle 10 Stunden empfohlen
- Track tensioning device, check before use, if the track becomes loose, please add butter immediately
Kettenspannvorrichtung, vor Gebrauch prüfen, wenn sich die Kette lockert, bitte sofort Butter zugeben

Filter name Filtername	The first time Time Zeit		das erste Mal maintenance mode Wartungsmodus		Normal Time Zeit		normalerweise maintenance mode Wartungsmodus	
	Air filter Luftfilter	50H		cleaning Reinigung		100H		replacement Ersetz
Diesel filter Dieselfilter	50H		replacement Ersetz		200H		replacement Ersetz	
Hydraulic oil filter Hydraulikölfilter	100H		replacement Ersetz		300H		replacement Ersetz	

 RIPPA service website: www.rippaservice.com
 (Webseite des RIPPA-Service)

(10) Company logo



(11) Test qualification identification



(12) Notes for operation, inspection, and maintenance



△ Instructions shall be read before operation, maintenance, decomposition, assembly, and transportation.

△ Be careful not to damage and lose.

(13) Start the switch recognition

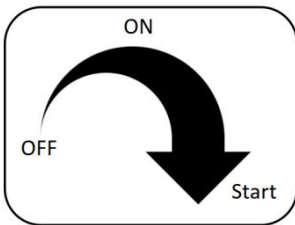

(14) Throttle adjustment

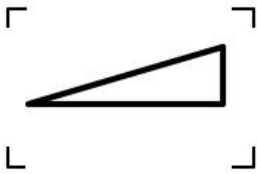

(15) Fuel oil filling port



△ Refueling at the specified location.

△ The engine should be closed when refueling and should be kept away from all open fires.

(16) Hydraulic oil filling port



△ The engine should be closed when refueling and should be kept away from all open fires.

(17) Never stand within the operating range



△ It is strictly prohibited to stand within the operating scope of the machine.

△ Note the rotation radius of the machine.

1. 4 Nameplate sign

nameplate model



Nameplate location

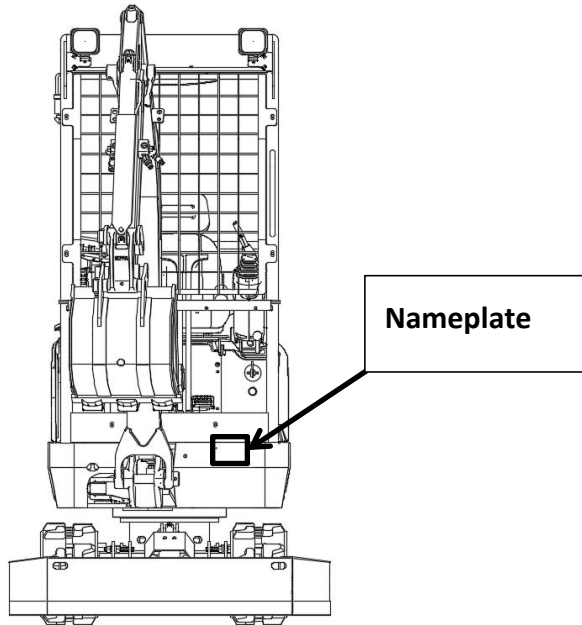

1. 5 Safety information

safe rules

Only the trained and instructed personnel can operate and maintain the machine. All safety rules, precautions, and instructions shall be followed when operating or maintaining the machine.

Under the influence of alcohol or drugs, can severely reduce/weaken the ability to safely operate or repair the machine, putting yourself and others at risk. When working with other operators or field traffic commanders, let everyone understand all the gesture signals used.

exception handling

If found abnormal (sound, vibration, odor, incorrect instrument display, smoke, oil leakage, etc., or abnormal alarm device or monitor display), should report to the supervisor in time, and take necessary measures. Do not operate the machine until the fault is corrected.

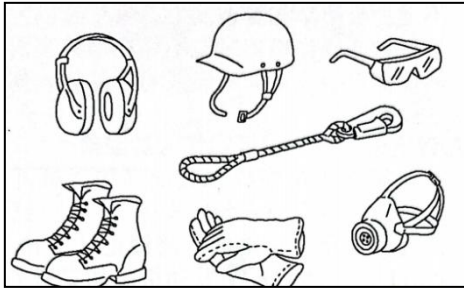

Operating personnel overalls and protective equipment

Do not wear loose clothes and accessories. The excavator has a suspension control lever or other protruding parts. If the hair is too long and the helmet may be wrapped in the machine, tie your hair up and be careful not to let your hair hang around the machine. Wear a safety helmet and wear safety shoes. Wear safety glasses, masks, gloves, earplugs, and safety belts if necessary when operating or maintaining the machine. Before use, check that all the protection devices function properly.

safe

Make sure that all the shields are in place. If the shield is damaged, repair it immediately.

Understand how to use the safety equipment, and use it correctly.

Do not remove any safety devices and keep them in good working condition.

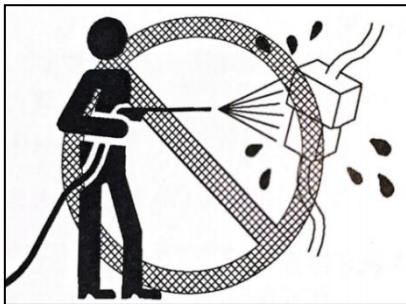

Keep the machine clean

1. If the electrical system is flooded, there is a danger of failure or failure. Do not flush the electrical system (sensors, connectors) with water or steam.
2. If the machine inspected and maintained has mud or oil, there is a risk of slipping and falling or dirt entering the eye.
3. Keep the machine clean at all times. Keep the operating position clean while driving,

and be sure to remove the mud and oil from the sole.

4. If the sole has mud or oil, the foot will slip when operating the pedal, causing serious fault problems.

Leave the operating seat after locking

1. Position the worker completely before standing from the operator seat (with the front or top window on or closed, installed, or when adjusting the seat), and place the operation lock in the locked position. Then turn off the engine.

If the lock, it may cause the machine to move suddenly and cause serious damage or damage to the device.

2. When leaving the machine, be sure to completely lower the working device to the ground, pull the operating lock firmly to the locked position, and then close the engine. Lock all the equipment with the key, remove the key, and place it in the designated position.

Armrests and ladders

To prevent personal injury from slipping or falling from the machine, follow the following requirements.

1. When going up and down the machine, please use the handrails and ladders marked in the drawing.

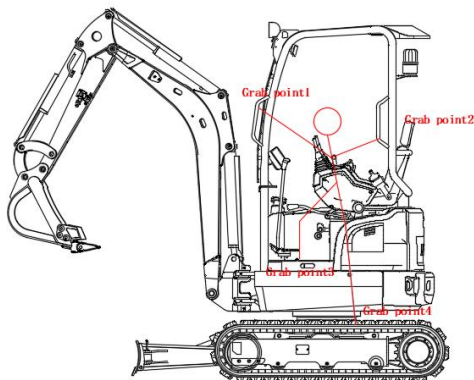

2. To ensure safety, face the machine, and keep three points (two feet, one hand, or two hands and one foot) in contact with the handrail and steps (including the track plate) to

support yourself.

3. Do not grasp the lever when on and down the machine.
4. Do not climb on the hood or guard without skid pads.
5. Check the handrails and steps (including rail plates) before going up and down the machine. If the handrail or ladder (including the rail plate) has oil, grease, or mud, wipe it immediately. Keep these parts clean. Keep these parts clean. If damaged, repair and tighten the loose bolts.
6. Never operate the machine when you have the tool in your hand.

Up and down the machine

1. Do not jump on or off the machine. Do not go up and down the machine when it is moving.
2. If the machine starts moving without an operator, do not jump on the machine and try to stop the machine.

Don't sit on the zodiac sign

Do not let anyone sit on a bucket, wood grab, or other gear because there is a risk of falling or causing serious injury.



coolant liquid

When checking or discharging the coolant, to prevent heat injury caused by hot water or steam injection, wait for the water to cool until you can touch the temperature of the radiator cover by hand. Even if the coolant is cooled, slowly release the radiator cover to drain the internal pressure of the radiator.

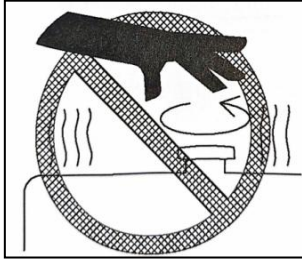

hot oil

When checking or releasing the oil, in order to prevent the oil from being ejected or causing burns caused by contact with the heating parts, please wait for the oil to cool down before touching the temperature of the cover or plug by hand. Even if the oil has cooled, slowly release the cover or plug to relieve the internal pressure before removing the oil cap.

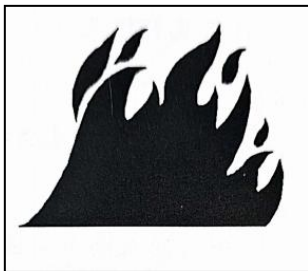

fire-proof and explosion-proof

The fire is caused by fuel oil or engine oil.



Fuel oil, oil, antifreeze, and window cleaners are very flammable and dangerous. To prevent a fire, the following provisions must be observed:

1. Do not smoke or use any open flame near the fuel or engine oil.
2. Turn off the engine before refueling.
3. Do not leave the machine when adding the fuel and engine oil. Fuel and machine tank caps are tightened.
4. Do not let fuel splash on overheated surfaces or components of the electrical system.

5. Oil or store oil in well-ventilated places.
6. The oil or fuel oil shall be stored in designated places and shall not be entered without permission.
7. After adding fuel or oil, erase the spilled fuel or oil. When grinding or welding on the lower car body, the flammable materials should be transferred to a safe place before starting.
8. When cleaning parts with oil, you should use non-flammable oil, diesel oil and gasoline are easy to catch fire, so do not use them.
9. Place tarpaulin or other flammable items in safety containers to ensure site safety.
- 10.No welding or cutting of pipes filled with flammable liquids.

Fire caused by the accumulation of flammable substances

Remove dry blades, wood chips, paper, dust, or other flammable substances that accumulate in or around the engine, exhaust pipe, muffler, battery, or hood.

A short circuit of the electrical system can cause a fire

1. Keep the wire contact clean and secure.
2. Check the wires for loosening and damage every day. Tighten loose joints or clips and repair or replace damaged wires.

The fire was caused by the hydraulic line

Check that all hoses and pipe clips, shields, and cushions are firmly in place.

If loose, it will vibrate and rub with other parts during operation, causing hose damage, high-pressure oil injection, causing a fire hazard, or serious injury.

An explosion caused by the lighting equipment

1. Check the fuel oil, oil, battery electrolyte, window cleaner, or coolant. If this lighting device is not used, there is a risk of serious injury from an explosion.
2. When the machine is used for lighting, follow this manual.

Action taken in case of a fire

In case of fire, call the following instructions and leave the machine quickly.

Turn the start switch to OFF and turn off the engine.

Use the handrails and steps to leave the machine.



Prevent falling, scattering, and intrusion

Falling protection devices (FOPS) or top jackets shall not be used in dangerous situations where falling objects are not installed.

Attachment installation

For safety or legal issues when installing the selected accessories or accessories, please contact our service staff in advance. Any injury, accident, or product failure due to the use of unapproved accessories or parts is not related to the plant.

When installing and using the selected accessories, read the instructions for the accessories and the general instructions in this manual.

The combination of accessories

Depending on the type or combination of the worker device, there is a risk of the worker device hitting the cab or other parts of the machine. Check for the danger of impact and operate carefully when used by unfamiliar workers.

Unapproved modification

Any modifications without plant approval are dangerous. Before the transformation, please contact the professional and technical service personnel.

The factory is not liable without the consent of the factory.

Before starting the operation, thoroughly check the work area for abnormal and dangerous conditions.

1. There is a risk of fire when operating near combustible materials (such as thatched roofs, dry leaves, or hay), so operate with caution.
2. Check the terrain and conditions of the ground at the work site and determine the safest operating procedures. Do not work in places with dangerous landslides or rockfalls.
3. If water pipes, water pipes, or high-voltage wires are buried under the work site, contact the utilities and indicate their location, and be careful not to break or damage any lines.
4. Take the necessary measures to prevent any unauthorized personnel from entering the work area.
5. When working on highways, arrange signal personnel and install fences to ensure the safety of traffic and pedestrians.
6. When walking or working on shallow water or soft soil, check the type and condition of rock strata and the depth and velocity of water flow before operation.

Working on the soft ground

1. Avoid walking or operating machines near cliff edges, embankments, and deep canals. In these areas, the ground is soft, and there is a danger of falling or overturning if the ground collapses under the weight or vibration of the machine. Remember these places change after heavy rain, blasting, or earthquake.
2. Working near embankments or ditches, there is a risk of soil loosening due to the weight and vibration of the machine. Take measures to secure the ground to prevent the machine from dumping or falling.

Ensure good visibility

To ensure safe operation or walking, check for personnel or obstacles around the machine and check the condition at the work site. Follow the steps below:

1. When working in a dark place, turn on the working lights and headlights installed on the machine, and set up auxiliary lighting in the working area if necessary.
2. If the view is bad, if there is fog, snow, rain, or dust, stop operating.



Ventilation of the enclosed areas

Engine exhaust gas can be fatal.

If the engine must be started in an enclosed area, or when handling fuel, cleaning machine oil or paint, doors and Windows should be opened to prevent gas poisoning to ensure adequate ventilation.

Signals and gestures of signalmen

1. Set up signs on an embankment or a soft ground. If the sight is not good, arrange a signalman if necessary. The operator should pay special attention to these signs and follow the instructions of the signalman.
2. Can only be sent by one signaler.
3. Before starting work, make sure all workers know all the signals, gestures, and cab emergency exits.

If inhaling asbestos dust in the air can cause lung cancer. There is a risk of inhaling asbestos when engaged in dismantling operations or handling industrial waste in the workplace. The following rules must be followed.

- (1) When cleaning, spray water to reduce dust, do not use compressed air cleaning.
- (2) If the air may contain asbestos dust, the machine must be placed in a prominent position, and all personnel should use qualified dust masks.
- (3) During the operation process, other personnel shall not approach it.
- (4) Abide by the rules regulations and environmental standards of the work site.

Chapter 2: Preparation before the work

Before operation, the vehicle condition and operation area should be fully understood to ensure safety.

2.1 Fuel volume inspection

Fuel quantity inspection

The fuel capacity of the vehicle shall be checked before operation. When the fuel is insufficient, the fuel should be replenished in time to avoid entering the air due to fuel depletion. The machine may not catch fire after refueling again. Due to the large differences in different climates of the machine, areas with low temperatures in winter must choose diesel suitable for the local temperature, such as the minimum temperature-20 degrees, diesel needs to choose-30 # diesel, otherwise diesel freezing will occur, it is difficult to start or unable to start the machine.

2.2 Track tension inspection

Before the operation, check the track tension. If the shoe is too loose, tighten the shoe (shown below). Different types of adjustment mouth forms are slightly different, but the position is roughly the same, with the real object prevailing.

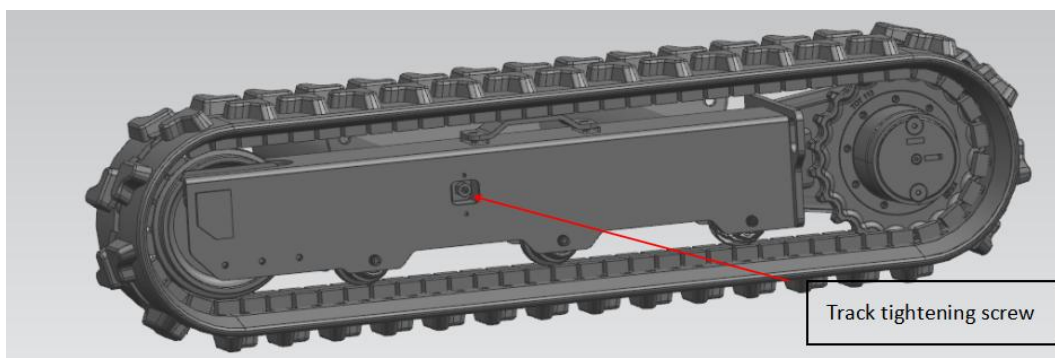

If the track is too loose, it is easy to fall off when turning, turning around, and walking on one side. Once the tracks fall off, it is very difficult to install.

2.3 Hydraulic oil and oil quantity inspection

Check the hydraulic oil for the level before the operation, If the hydraulic tank level is too low or the fuselage tilts, will cause the oil pump not to absorb oil and the vehicle without any action (action stalled, the oil pump and the hydraulic pump are seriously worn or even damaged), you need to add hydraulic oil or level the body, if there is no hydraulic oil or can not level the body, you can try to operate the control lever, lift the big arm to the body, then start the machine, if any action, first transfer the car to the level, and then supplement the hydraulic oil.

Hydraulic oil inspection

The hydraulic oil used in this excavator is 46 # (specific gravity 0.8 / viscosity index 47) anti-wear hydraulic oil. Due to the use of the area

The too-low or too-high temperature will affect the viscosity of the hydraulic oil, resulting in the system pressure not

Foot or abnormal, or even accelerate the wear of the oil pump. Special climate areas (too cold or overheated) should be combined with the local climate

Conditions to select the hydraulic oil suitable for the local temperature. In response to the loss of excavator performance caused by hydraulic oil in special environment

For safety issues, the following is the reference scheme for the selection of hydraulic oil at special ambient temperatures:

- ① When the working environment temperature is lower than -18°C , it is recommended to replace the low-temperature and ultra-low-temperature anti-wear hydraulic oil;
- ② When the working environment temperature is $-5^{\circ}\text{C} \sim -18^{\circ}\text{C}$, it is recommended to replace the 32 # anti-wear hydraulic oil;
- ③ When the working environment temperature is higher than -5°C , the customer does not need to replace the hydraulic oil separately without special circumstances;

Warning: Waste hydraulic oil should be treated according to local regulations, do not dump it.

Note: When the machine cooler starts, due to the low temperature of the hydraulic oil, the hydraulic oil is relatively sticky and easy to bubble, which is a normal phenomenon. When the vehicle starts and runs, the bubbles will gradually dissipate as the temperature of the hydraulic system rises.

Oil and oil volume inspection

Check the engine oil before the operation, check whether the oil is sufficient (because the machine works climbing, downhill, incline, and other conditions, so the oil should be close to the oil gauge limit to prevent the pump pumping), and supplement in time, (it is necessary to check the oil volume regularly because the engine works slowly) otherwise it will cause the engine to wear or pull the cylinder, due to the lack of oil or other problems; the engine manufacturer does not guarantee.

2.4 Check the lubrication point

The excavator shall check each lubrication point before operation. Generally, butter should be added at each lubrication point every 48 hours. The filling amount should be sufficient, and the filling number should be increased when the working conditions are poor.

2.5 Check the tightness of the fixing bolts for important parts

Important components include rotating brackets, rotating motors, and engines. The fixing bolts of these parts should be checked for loosening before operation. If the bolts are loose, they must be tightened immediately. If necessary, please consult the manufacturer. Failure to check or tighten the loose bolts may cause serious problems such as the rotating bracket and rotary motor gear interruption, engine loss, and fan and water tank damage.

2.6 Oil leakage inspection

Before operation, observe the vehicle and check whether the excavator chassis has oil leakage. If so, it shall be fixed or repaired in time.

2.7 Check the operation area

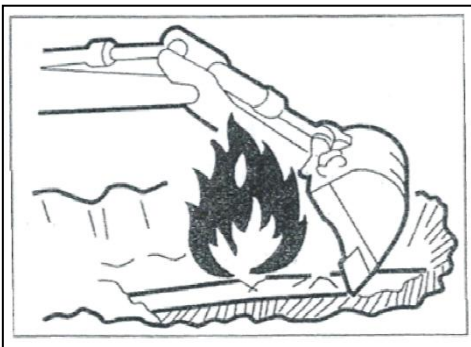

1. Check the terrain and ground conditions in the operating area and do them indoors.
2. Inspect the building structure and take safety measures if necessary.
3. Avoid walking in ditches, underground pipes, trees, cliffs, and shelves.
4. Wire or hazardous areas, such as rockfall or landslides.
5. Check with the administrator for the location of the buried gas pipes, water pipes, and power lines. If necessary, it must be resolved through consultation to ensure safety.
6. Full range of specific safety measures.
7. When working on the road, be sure to consider the safety of pedestrians and vehicles, and use signalmen or signals. Isolate the operation area and prohibit unauthorized personnel from entering.
8. When working in water or crossing shallow streams, the water depth and the ground are solid and the flow speed should be checked in advance.

2.8 Check the strength of the bridge

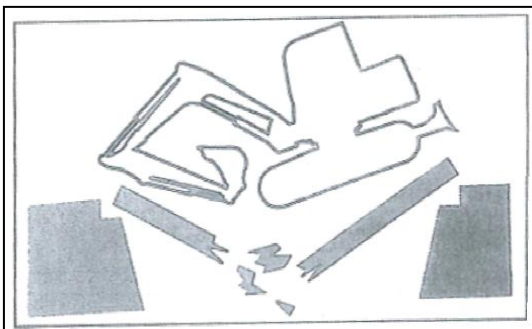

On a bridge or the buildings.

If the strength is insufficient, the bridge or building should be reinforced.

2.9 Always keep the machine clean

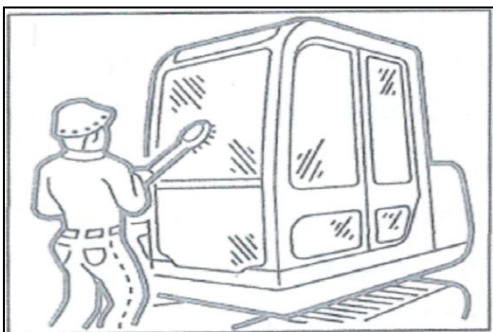

1. Wipe off oil, grease, dirt, snow, or ice to prevent skid skid.
2. Remove all loose objects and unnecessary equipment from the machine.
3. Remove dust, oil, or grease from engine parts to prevent fire.
4. Clean the operating valve seat to remove any unnecessary condition in the machine.

2.10 Routine inspection and maintenance

A normal condition or damage not identified (or not repaired) of the machine will cause failure. Before the operation, please inspect and repair as required immediately, if necessary.

In case of an accident or engine failure, stop immediately until the fault is resolved.

2.11 Use of the bucket

The bucket capacity used is 0.0 45 m 3.

Warning: Note the quality and volume grade of the bucket; consider the density of the material.

Chapter 3: The Safe Operation of the Machine

3.1 Start the engine

With a warning sign on the lever, do not start the engine or contact the lever.

Pay attention to

Personnel must undergo necessary training, familiarity with potential hazards, and problem-solving skills.

Only the trained and authorized personnel can operate and maintain the machine.

Operators shall be trained to operate and maintain in strict accordance with this manual.

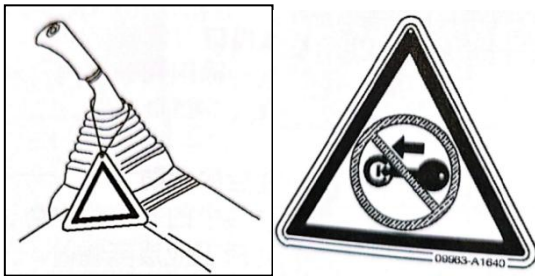

3.2 Preparation before startup

Turn on the main power switch before starting the engine and turn the start switch. After the engine speed reaches, press the start button immediately to confirm whether the start key returns.

Do not turn the key after the engine starts. This operation can damage the starting motor and the engine flywheel gear, and even destroy the starting housing and burn the starting coil. In addition, excessive turning of the fire key will cause the key to not rebound. After the engine starts, the starting gear cannot be separated from the engine. With the engine running at high speed, the current in the starter rises quickly, causing the coil to burn out.

Start the key with dust, can effectively avoid dust water, and other substances in the key,

once there are water and other impurities in the key, can lead to the lock core stuck or an internal short circuit, damage the starter, so in the rainy day or wet, dust outside more environment to avoid parking keys for a long time, if you need to park must take protective measures to the key.

Special note: the diesel engine can not start after 10 seconds, please wait 15 seconds before starting (continuously starting the power supply for a long time leads to a lot of battery consumption, and the starter may burn out). The above phenomenon may cause the starter damage.

Winter start mode: the model has the preheating function. When the weather is too cold, the key switch must be turned backward and stored for 8~10 seconds (can not be used for a long time, otherwise the battery will cause power loss), and then start the engine normally.

After startup, the power master switch and the 1-gear key are turned on, otherwise the battery cannot be charged.

After starting the engine, the following operations and inspections shall be performed where there are no personnel or obstacles. If a fault is found, stop down and report the fault according to the procedure.

1. Preheat the engine and the hydraulic oil for 5-10 minutes.
2. Check the instrument and alarm equipment for normality.
3. Check it out for any noise.
4. Test the engine speed.
5. Do not use ether or starter fluid on the engine. Starting fluid may lead to explosion and serious injury or even death.
6. Preheat the engine and the hydraulic oil. If the control lever is operated without preheating, the machine will not be able to react or move quickly or accurately, causing an accident.

3.3 Operation

Check after starting the engine

During the inspection, move the machine to a wide place without obstacles and run slowly. No one is allowed to approach this machine.

Be sure to fasten your seat belt.

Check that the machine motion is consistent with the display on the control mode card.

If not, immediately use the correct control mode.

Check the operation of the instruments and equipment, and check the operation of the bucket, bucket pole, boom, walking system, swing system, and steering system.

Check for sound, vibration, heating, odor, or instrument for leakage of oil or fuel.

3.4 Setting of the Workstation

get on

1. Get from the left and the operator pulls the lock up.
2. Move the operation lock up to the end position.
3. Put your hand on the designated handle and push down the step into the car.
4. Rotate and sit in the seat operating position.

Adjust the driver's seat

The driver's seat shall be adjusted to a non-fatigue and comfortable working condition. All of the control elements must be capable of operating safely. Seat longitudinal adjustment (seat spacing).

Pull the seat longitudinal lever, push the seat back, release the lever, and adjust the seat position. Note: Make sure the seat is fixed.

Spring force adjustment

The air seat weight can be adjusted by rotating the seat front knob.

1. Increase the spring tension by rotating the regulating valve clockwise to accommodate

the weight of the heavy operator.

2. The spring tension is reduced by rotating the control valve counterclockwise to accommodate the weight of the light operator. Use the above method to adjust the seats to achieve good suspension comfort.

Backrest adjustment

Gently remove the back and lift the lever to the left of the seat. The joystick was released by leaning forward or backward to adjust the desired sitting position. The backrest should be adjusted in such a way that the operator can operate the lever safely when the back is completely against the back.

Note: The highest MS value of whole-body vibration is 0.5 m/s². The uncertainty of the whole-body vibration measurement was 0.1 m/s².

life belt

1. Tie up your seat belt.
2. Make sure that the seat belt is secure.
3. Note: Do not operate the excavator without wearing a seat belt.

3.5 Check the rearview mirror

Check the rearview mirror settings to see for the best viewing position. If not, you can adjust the left and down of the mirror by moving the mirror housing until the best view position is ensured.

Clean the mirror: Use wet or dry cotton cloth or sanitary paper towels, to wipe the mirror and frame from left to right and from top to bottom until the mirror is clear. Clean up and adjust the rearview mirror to the proper position.

3.6 Description of the display and operation unit

The switches of the display and operating units are versatile and can also be used for menu navigation in the display. Each function is described in detail in the respective

sections.

1. Oil supply indicator

The oil supply indicator shows the relative amount of fuel in the tank.

2. charge lamp

When the charging circuit voltage is insufficient, the charging indicator light is on.

3. The engine oil pressure indicator light is on

When the oil pressure is below the set value, the oil pressure indicator light is on.

3.7 Other equipment in the driver's seat

Additional equipment located in the cab is described below.

Directive box

The instruction box is located directly in front of the console.

The gauge adjustment button

If the excavator is equipped with a gauge adjustment device, the track width of the excavator shall be 9 89mm ~ 13 09 mm.

Place the warp switch in the expansion gear, then step on the bulldozer pedal and step forward to extend the track and back to narrow the track.

oil level detector

The fuel indicator lamp is located on the left side of the seat to determine the fuel level by observing the pointer on the indicator lamp. Unscrew the oil gauge, remove the oil gauge to prevent the oil bucket from emerging, and then fill.

The battery disconnects the switch

Open the main circuit. The battery disconnection switch is located on the left side of the seat and marked with the power off switch.

horn switch

The horn switch is used to control the opening and closing of the horn and plays a warning role through the horn. The horn switch is located at the center push button of the right operating handle.

3.8 Overview of control lever functions (default setting)

The function of the left and right joystick is shown in Fig.

controller		movement
Right joystick	1	Put down the arm
	2	Raise the cantilever
	3	Put away the bucket
	4	Open the bucket
Left joystick	A	Put down the pole
	B	Raise the pole
	C	Rotate the cab to the left
	D	Rotate the cab to the right

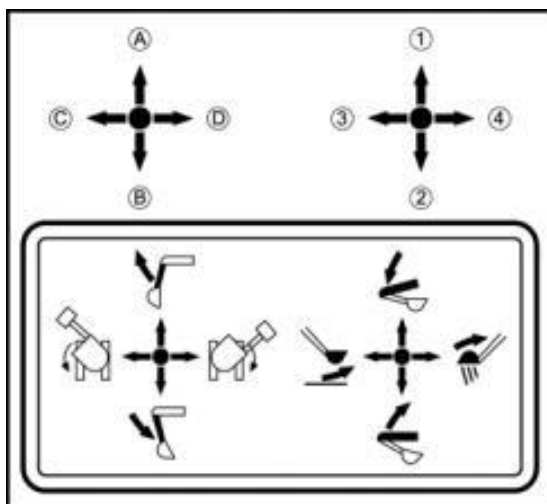

Move the arm operation

When the excavator is overloaded, be sure to put down the boom until the load reaches the ground. To raise the boom, pull back using the right lever. To lower the active arm, use the right lever to push forward.

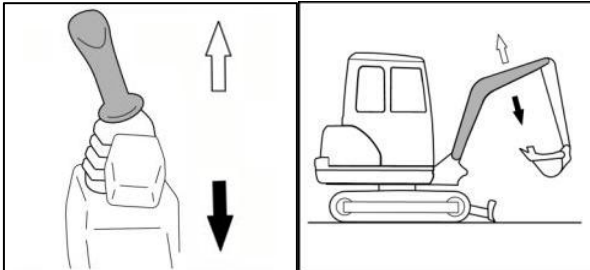

Pour:

The total value of the boom vibration is 2.5 m/s².

The uncertainty of the boom vibration measurement is 0.5 / s².

Note: Observe the boom assembly while lowering to ensure there is no personnel or cargo under the boom.

Operation of the bucket pole

To lift the lever, push the left lever forward and pull the left lever backward.

The control lever moves, as shown in Fig.

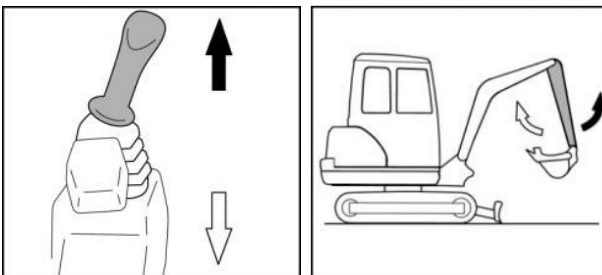

Lift the bucket and pull left using the right lever. To clear the bucket, push right using the right lever.

When loaded into the bucket, make sure that the bucket teeth do not bump into the front plate of the bulldozer.

The bucket moves, as shown in Fig.

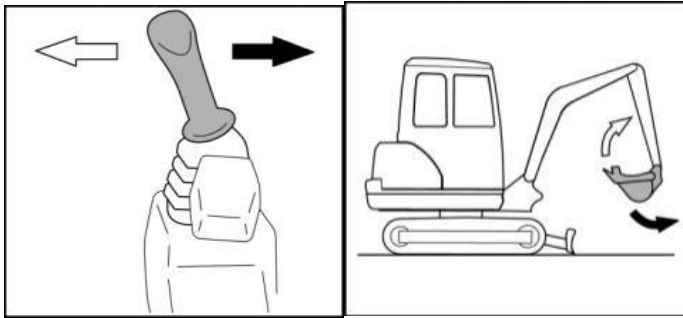

3.9 Ceiling

The ceiling is a specially designed and manufactured frame that is installed in the cab of a vehicle (sometimes in this case called an outer cage) to protect passengers from injury or death in accidents, especially in the event of a rollover.

The suspended ceiling is a pressure protection device. If there is deformation, welding, distortion, and other phenomena in daily use, please contact the factory for replacement in time. Don't risk it out there.

Removing process

1. Fixed the rope on the binding point of the ceiling, so that the lifting equipment is lifting.
2. Remove 2 M1 2 screws at the front end of the ceiling and 3 M1 2 screws at the back end of the ceiling respectively.
3. Operate the equipment and slowly raise the ceiling.
4. Move the ceiling to the left/right and then slowly to complete the disassembly.

Installation steps

1. Attach the rope to the binding point of the ceiling.
2. Slowly lift the device, raise the ceiling, and move it to the mounting position.
3. Use the bolts to fix the mounting hole of the ceiling to ensure that the ceiling does not tilt or shake on the machine.
4. Release the binding point of the lifting device and complete the installation.

3.10 Rotational safety precautions

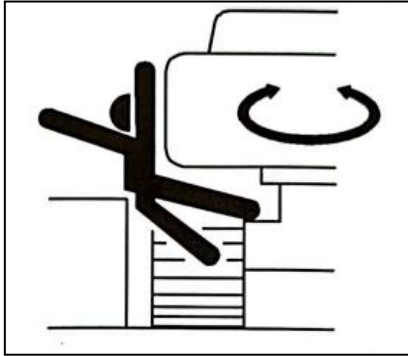

1. Before driving, place the machine to keep the bulldozers in front of the driver's seat. If the bulldozing is behind the cab, move the machine in the opposite direction (walk back and forth, turn left and right). Pay special attention when operating the machine in this case.
2. Before walking, please check whether there is no one around, and whether there are obstacles.
3. Before walking, honk your horn to remind the people around you.
4. The machine can only be operated on the seat.
5. No one except the operator shall ride on the machine.
6. Check whether the walking alarm equipment is working properly.
7. When the machine is running or turning, take special care not to touch other machines or personnel.
8. Observe the above precautions even if the machine has a rearview mirror.

3.11 Safety precautions for travel

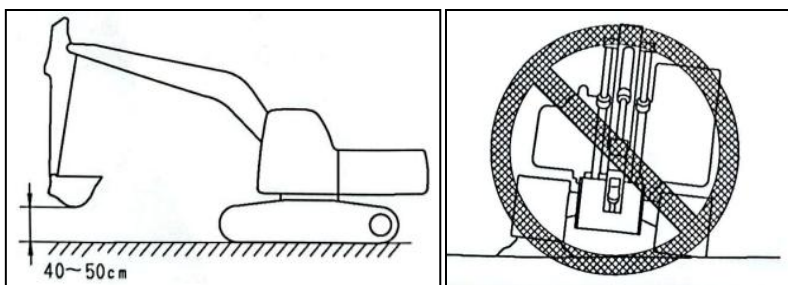

1. When walking on flat ground, the working device shall be 40~50cm (16~20 inches) above the ground.
2. When walking on rugged ground, walk at a low speed, and do not suddenly operate the steering, so as not to cause the danger of machine rollover. The working device will hit the ground, take the machine out of balance, and damage the machine or structure.
3. When walking on rough ground or steep slopes, if the machine is equipped with an automatic deceleration device, turn the automatic deceleration switch off (cancel). If the automatic downshift switch is turned on, the engine speed will increase and the walking speed will suddenly increase.
4. Try to avoid walking on the obstacles, if the machine must walk on the obstacles, keep the working device close to the ground and walk at a low speed. Do not walk fast on the road.
5. Always keep a safe distance from people, buildings, or other machines and avoid contact with them.
6. When passing through a bridge or building, first check whether the structure is strong enough to support the weight of the machine.
7. When walking on the highway, first ask the relevant authorities to check and follow their instructions.
8. When operating in tunnels, under bridges, underwires, or in other places of limited height, operate slowly and take special care not to let the working device touch anything.

3.12 Walking on the slope

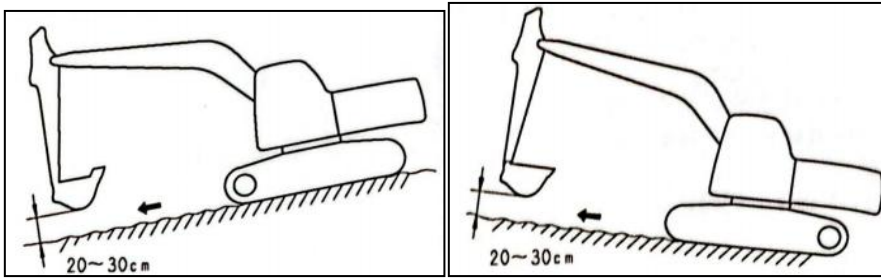

To prevent the machine from overturning or sliding, follow the following requirements. When walking on a slope, the working device should be kept 20 ~ 30 cm (8 ~ 12 inches) from the ground. In an emergency, the working device can be quickly lowered to the ground to cause the machine to stop working.

When walking uphill, turn the cab uphill and then downward when going downhill. When walking, check the hardness of the ground in front of the machine. When climbing a steep slope, the working device should be extended forward to increase the balance, so that the working device should be kept 20 ~ 30cm (8 ~ 12 inches) off the ground and walk at a low speed.

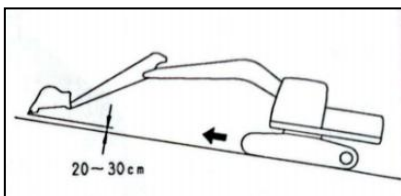

On the current slope, reduce the engine speed to approach the lever to the "middle" position and walk at a low speed. It is dangerous to walk up and down a straight line, or turn on or across a slope.

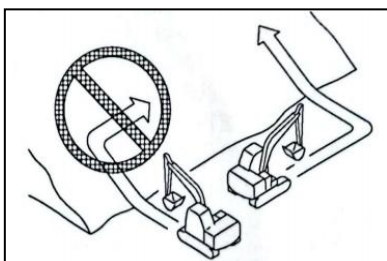

Do not turn around or cross the slope. Be sure to go down to a flat place, change the position of the machine, and then go up the slope. Walk at low speeds on grass, deciduous or wet plates, even on small slopes, at 130 degrees.

If the engine stalls while the machine is walking on the slope, immediately move the lever to the "middle" position to restart the engine.

3.13 Operation on the slope

When working on the slope, the machine is in danger of losing balance and overturning while operating the rotation or working device. This can cause serious personal injury or equipment damage. Follow the following principles:

1. When performing these operations, a flat area should be provided with great care.
2. When the bucket fills the side, do not turn the working device from the uphill side back to the downhill side. This operation is very dangerous and will overturn the machine.
3. If the machine must be used on the slope, stack up as many platforms as possible (A).

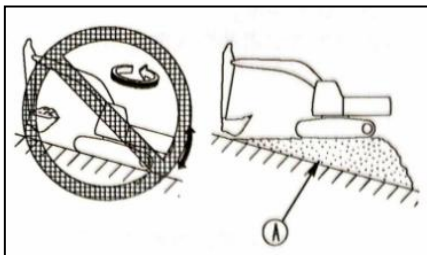

3.14, prohibit operation

1. Do not dig the face below the suspension part, which poses the risk of falling rocks or hitting the machine.

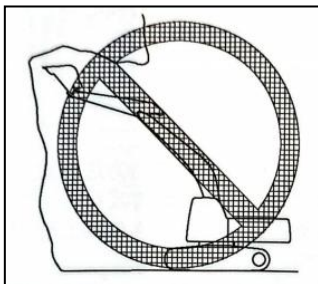

2. Don't dig too deep in the front and bottom of the machine. Otherwise, the ground below the machine may collapse, causing the machine to fall.

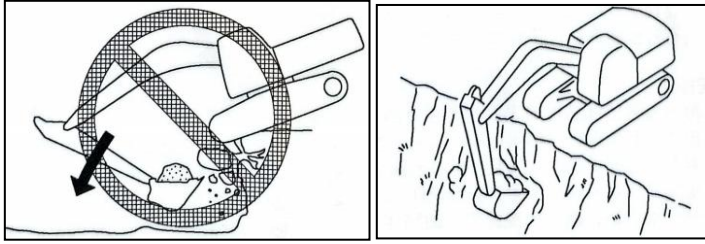

3. When excavating, adjust the track to a right angle to the shoulder or cliff. While the sprocket was in the rear position, making the machine easy to withdraw in any case.

4. Do not dismantle the operation under the machine, which will make the machine unstable and have the risk of tilt.

5. When working on the upper part of a building or other structures, the strength of the structure shall be checked before starting the work. Avoid the danger of a building collapsing and causing serious injury or damage.

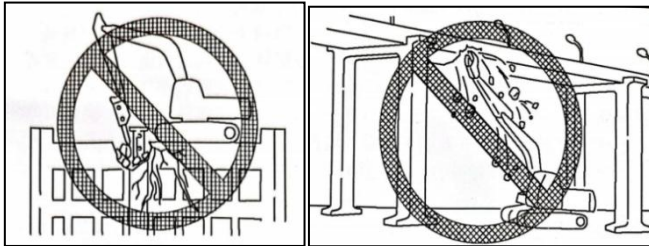

6. Do not remove the pin shaft when removing it. This causes the risk of falling broken parts or the collapse of the building and causes serious injury or damage.

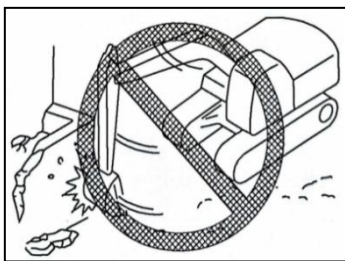

7. Do not use the impact force of the working device to break the object, there will be personal injury or damage to the working device.

8. In general, the working device is more likely to roll over on the side than it is in front or behind.

9. There is a risk of loss of balance and dumping when using crushing hammers or other heavy working devices. When operating on flat ground and slopes: do not suddenly fall, turn, or stop working devices. Do not suddenly extend or withdraw the moving arm. This is easy to cause the risk of the machine being overturned due to the impact.

10. Do not place the bucket over the heads of other workers or above the operator's seat of

the dump truck and other transport equipment. Since the load is likely to fall, the bucket may hit the dump truck, causing serious injury or damage.

3.15, snow day work

1. Snow-covered or icy roads are slippery. When walking or operating the machine, take special care not to suddenly operate the control lever. Even small slopes can skid the machine, so pay special attention when working on the slope.
2. For the frozen ground, when the temperature rises, the ground becomes soft, causing the machine to roll over.
3. If the machine enters the deep snow, it is a danger of turning over or being buried in the snow. Be careful not to leave the shoulder or roll over in the snow.
4. During snow removal, objects are buried in the snow on the shoulder and near the road and can not be seen. Therefore, there is a danger of the machine hitting the buried object. Therefore, it must be operated carefully.

3.16 Parking

1. Place the machine on a solid, flat ground.
2. Choose a place with no risk of rockfall or landslides, or with no risk of inundation.
3. Put the working device down to the ground.
4. When leaving the machine, pull the operation lock to the locked position and close the engine.
5. To prevent unauthorized personnel from moving the machine, close the cab door and lock all the equipment with the key. Take off the key, carry it around, and place it in a designated place.
6. If the machine must stop on a slope, please follow the following rules.
 - (1) Adjust the bucket to the downhill side and insert the bucket into the ground.
 - (2) Place liners under the track to prevent machine movement.

3.17 Transportation

To facilitate transportation, the machine can be divided into several parts. Therefore, when transporting the machine, please contact the factory for this work.

3.18 Installation and unloading of the machines

When loading and unloading the machine, the machine frequently turns or falls, so special care must be taken. The following must be done:

1. Can only be installed and unloaded on hard, flat ground. Keep a safe distance from the roadside or from the cliff edge.
2. Do not install or unload the machine together with the working equipment. The machine is at risk of falling or overturning.
3. Use a springboard with sufficient strength to ensure the width, length, and thickness of the springboard to provide a safe handling slope.
4. Ensure that the springboard surface is clean and free of grease, oil, ice, and loose material. Remove the dirt from the machine tracks. Especially on rainy days, because the surface of the springboard is very slippery, be extra careful.
5. Close the automatic deceleration switch (the automatic deceleration function is canceled). Start the engine at a low speed and drive slowly. When on the springboard, do not operate any control lever other than the walking bar.
6. Do not correct the direction on the springboard. If necessary, drive out of the springboard, correct the direction, and then drive back to the springboard. At the connection of the springboard to the track or trailer, the center of gravity of the machine suddenly changes, putting the machine in danger of losing its balance. Slowly pass through the junction.
7. When loading and unloading on the subgrade or platform, ensure that the subgrade or platform has the appropriate width, strength, and slope. When turning the superstructure of the trailer, the trailer is unstable, making the working device exit and rotate slowly.
8. Machine equipped with the cab, install the machine and lock the doors. If not, the cab door will suddenly open during transit.

3.19, and the transport machine

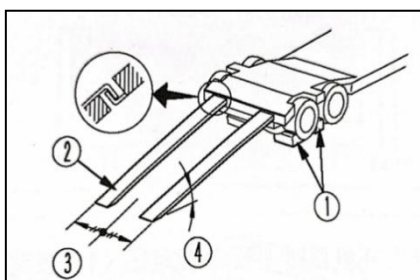

(1) pad (2) springboard (3) trailer center line (4) set the Angle of the springboard

When transporting the machine on the trailer, do the following.

1. The weight, transport height, and total length of the machine vary according to the working device, so be sure to confirm the size.
2. When passing a bridge or building on private land, it is first checked whether its structure is sufficient to support the weight of the machine. When walking on an expressway, the relevant administrative authorities shall first inspect and follow their command.
3. The transport machine shall be hoisted and bundled according to the position point of the following figure.

Machine recovery: If the excavator is trapped, use the crane to lift the whole excavator for recovery, operate according to the lifting procedure, and pay attention to using the correct lifting point.

3.20 The bucket lifting operation

Generally prohibit using standard specification machines for lifting operations.

Shovel bucket lifting.

Hoisting operations are usually prohibited. However, if the operation is specified and only specified, bucket lifting is allowed.

Safety rules for lifting objects.

1. Do not perform hoisting operations on slopes, soft ground, or other places where machines are unstable.
2. Use a standard conforming wire rope. Do not exceed the specified lifting load.
3. This is very dangerous if the load hits a person or a building. Check the surrounding area for safety before the machine turns 1 / 4 laps.
4. Do not suddenly start, turn, or stop the machine so that the increased load is in danger of rocking.
5. Do not pull the load to one side or toward the machine.
6. Do not lift the operator's seat when lifting the load.

The maximum allowable lifting load of this machine is shown in the following figure.

Stability calculation table, with a horizontal column for the force arm, bending moment, bending moment, a vertical column for the length (track bracket), vertical extension

(shovel), and horizontal bar.

The load lifting moment table is divided into two tables, the first table is static working condition and the second table is dynamic working condition. The vertical axis is the load height, the horizontal axis is outside each distance, CF is the bucket fall Angle, and CS is the bucket rise Angle.

Lift capacity ratings	
A: Load radius	Conditions of operation
B: Load point height	940mm Big arm
C: Lift capacity ratings	1780mm ARm
Cf: Rated loads over front	weight: 1818kg
Cs: Rated loads	Track width: 230mm
(Unit: kg)	Track spacing: 840mm

Load point height (Unit: m)	Load radius A (Static-bulldozer support)								
	1.5		2		2.5		Max		
	Cf	Cs	Cf	Cs	Cf	Cs	Cf	Cs	A (mm)
1.5	565	628	407	383	388	304	330	222	3201
1	686	647	521	388	449	298	334	220	3300
0.5	804	571	635	394	454	286	339	218	3376
0 (Grade)	934	616	683	438	481	301	423	230	3317
-1	948	635	583	453	508	323	438	258	2862
-1.1	962	704	538	464	525	340	454	274	2784

Chapter 4: Basic parameters of the excavator

4.1 Basic parameters

Name of the Main structural part (R18-4)

order number	name
1	cardinal tooth
2	dens lateralis
3	bucket
4	connecting rod
5	rocking bar
6	Dig bucket cylinder guard plate
7	Dig bucket cylinder
8	dipper
9	Dunk cylinder guard plate
10	The bucket pole cylinder
11	swing arm
12	Move the arm cylinder guard plate.
13	Move the arm cylinder
14	work light
15	Ceiling protection net
16	caution light
17	seat
18	shield
19	bob-weight
20	rubber belt track
21	Drive the chain wheel
22	Walking motor
23	thrust wheel
24	Guide the wheel
25	dozer blade
26	liquid crystal display
27	Turnpike handle
28	Lead operation handle
29	Walking operation rod

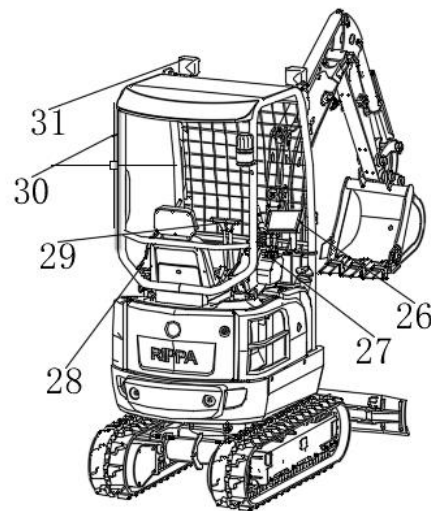
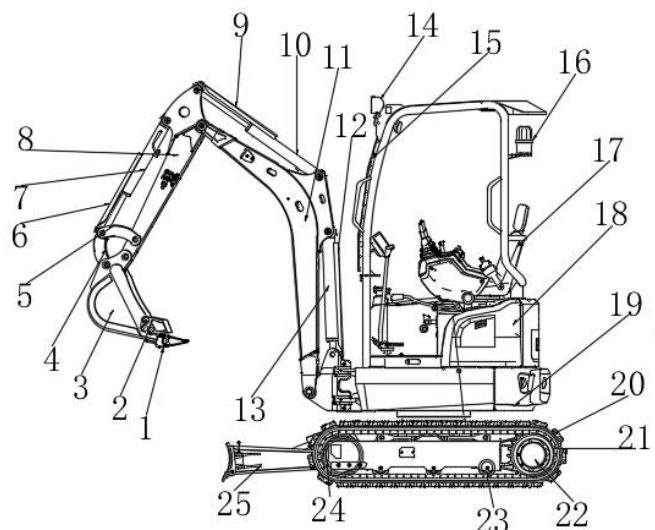

30	Ceiling frame	
31	work light	

4.2 Hinge connecting pin of the machine working device

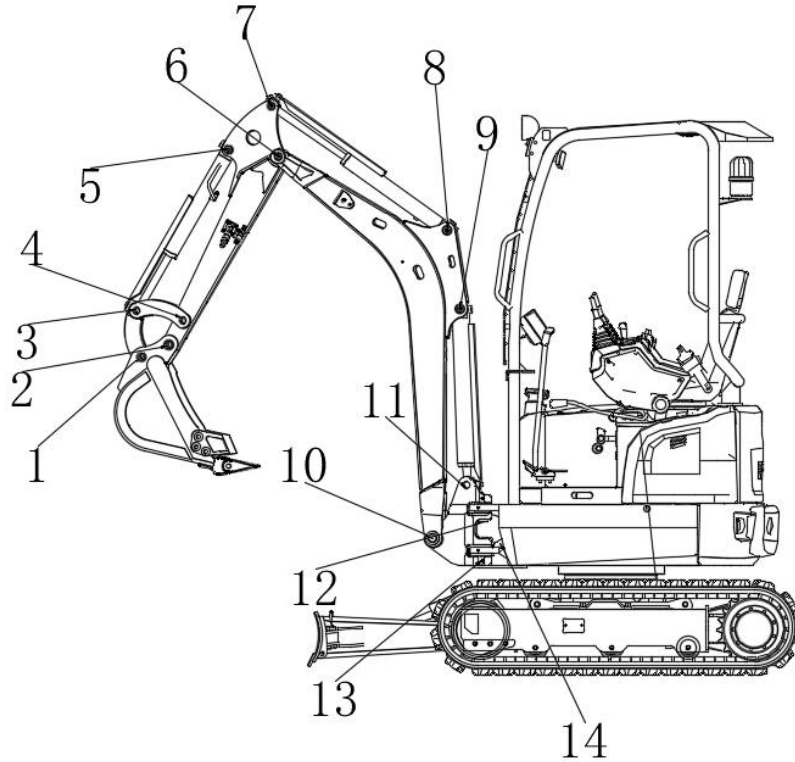

Machine pin shaft position indication (R18-4)

order number	The pin shaft connection
1	Connect the pin shaft
2	The dig bucket and the bucket rod connect the pin shaft
3	The rocker, connecting rod, and the bucket cylinder connect the pin shaft
4	The rocker connects the pin shaft to the bucket bar
5	Connect the bucket cylinder and the pin shaft
6	The boom connects the pin shaft
7	The barrel cylinder connects the pin shaft with the barrel cylinder
8	Connect the boom cylinder to the boom with the pin shaft
9	The boom cylinder connects the pin shaft to the boom
10	Connect the boom to the boom holder
1 1	The boom cylinder connects the pin shaft to the boom bracket
1 2	The boom bracket connects the pin shaft 1 to the upper disc
1 3	The boom bracket connects the pin shaft 2 to the upper disc

4.3 Main Dimensions and Specifications

Main excavation scope direction of excavator

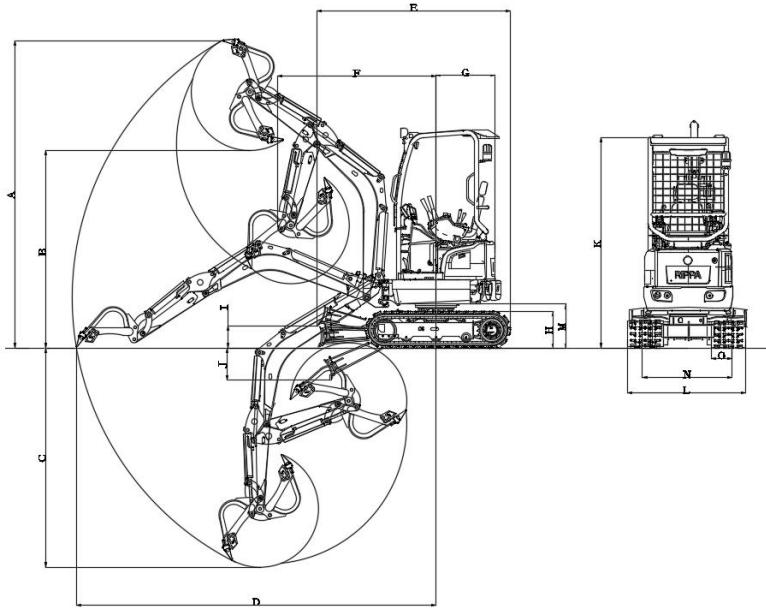

(R18-4)

working range		unit: mm
		R18-4
A	Maximum ground excavation height	3396
B	Maximum unloading height	2182
C	Maximum mining depth	2420
D	Maximum range of ground activity	3975
E	Transportation length	2775
F	radius of gyration	1751
G	Minimum tail radius of rotation	699
H	orbit altitude	407
I	maximum height of lift	475
J	Maximum sinking height of the bucket	3 5 5
K	Total body height	232 2
L	Total body width	98 9

M	The height of the body	486
N	The width of the push shovel	1309
O	Track width	230

4.4 Hydraulic schematic diagram and detailed information

As an important part of the hydraulic system design, its function is to clearly show the working principle, structure, and control mode of the hydraulic system. According to the hydraulic oil path of the hydraulic schematic diagram of the machine, the hydraulic pipeline problem can be better solved.

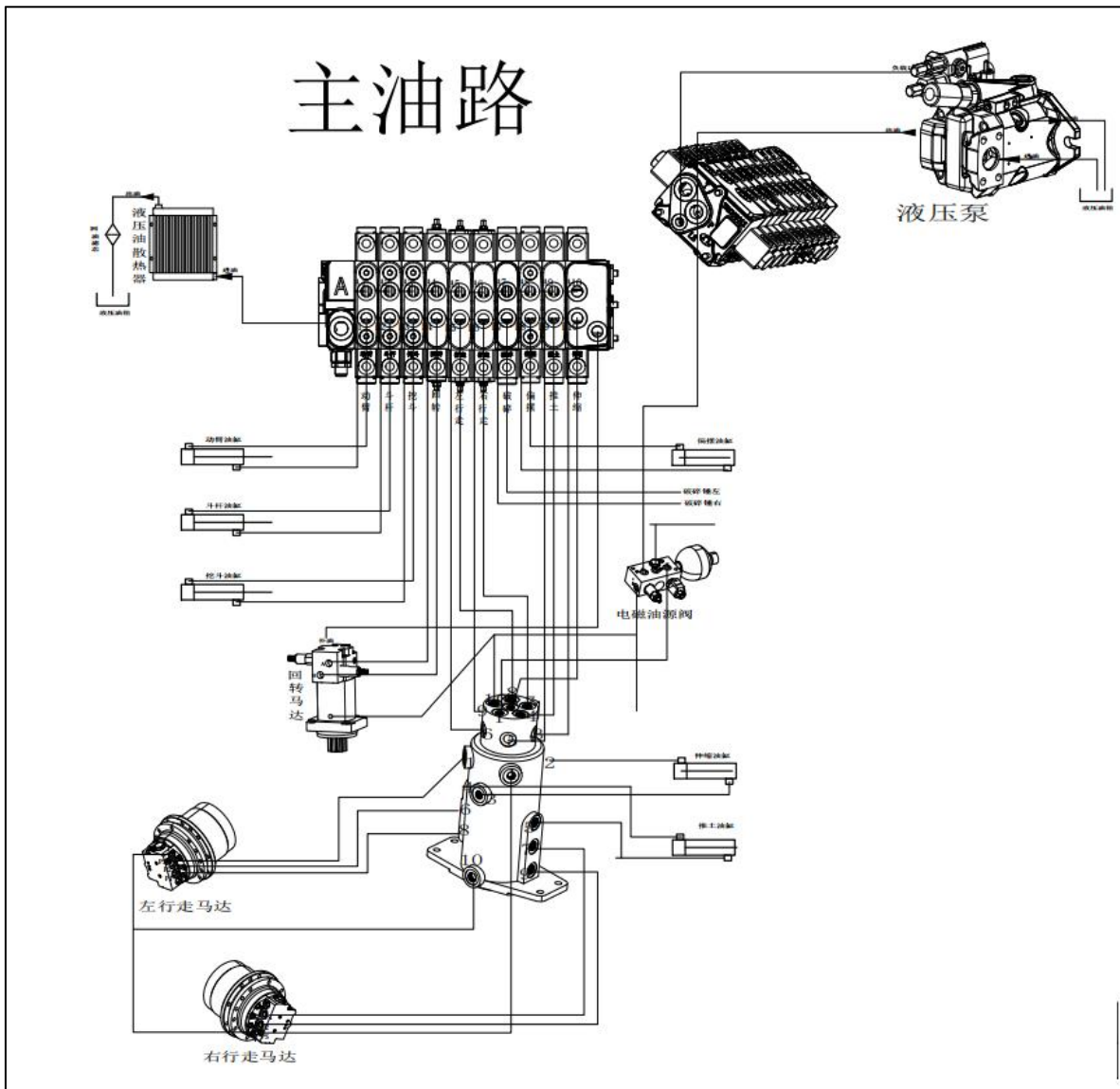

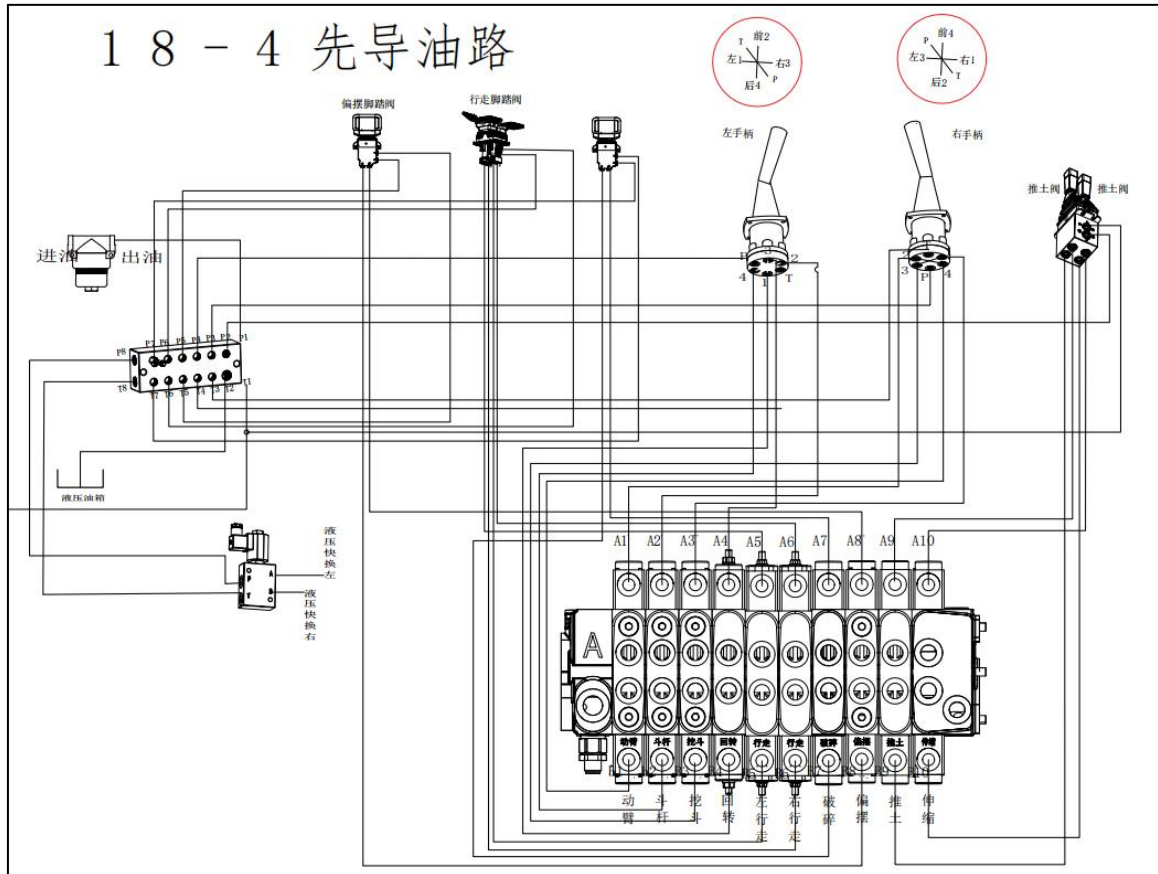

4.5 Electrical schematic diagram and details

Electrical schematic diagram

As an important part of the circuit design, the electrical schematic diagram is used to clearly show the working principle, structure, and control mode of the circuit. According to the electrical schematic diagram, you can have a comprehensive understanding of the electrical layout of the machine, and it can also be used for the investigation of electrical problems.

4.6 Excavator parameter table

Model information configuration status ● Standard matching and selection			R18-4			
fundamental performance parameter	Operating weight (kg)	1818	engine	engine type	JBT D902	
	Configuration (m ³)	0.045		maximum horsepower (ps)	16.1	
	Low / High walking speed (Km/h)	0-1.5/0-2.8		maximum power (Kw)	11.8	
	Climbing ability of (%)	30%		Maximum rotational speed (rpm)	2300	
	Ground-to-ground ratio pressure (Kpa)	30.33		displacement (L)	0.898	
	Maximum excavation (kN)	12.8		The number of cylinders	3	
	Maximum excavation radius (mm)	3975		cooling-down method	hydro cooling	
	Maximum excavation depth (mm)	2420		Engine oil replacement volume (L)	3.7	
	Maximum excavation height (mm)	3396		Fuel form	diesel oil	
	Maximum discharge height (mm)	2182		Fuel label	No. 0/-10	
	maximum deflection angle (°)	111		Theoretical fuel consumption (L/h)	1.5-1.8	
	Crawler expansion range (mm)	989-1309		body of car	Transport Length (mm)	2430
					Transport Width (mm)	912
		Transportation Height (mm)	2201			
		Counterweight and ground clearance (mm)	361			
		Bucket width (mm)	300			
		Boom Length (mm)	1477			
		Bucod length (mm)	800			
configure	pilothouse	-	bullet plate width (mm)	912-1212		
	handrail	-		fuel tank	fuel tank (L)	5.5
	Quick change	○				
	Hydraulic fast change	○				
	rabble	○				
	log grapple	○				
	ridge	○				

	quartering hammer	○		hydraulic oil tank (L)	12.5
	bob-weight	●	track	-Rubber (bandwidth * pitch * number)	180*72*37
	Zhang tight form	The butter is tight		-Steel (bandwidth * pitch * number)	180*72*37
	air-conditioning	-		Rubber block (piece)	74
hydraulic pressure system	Main pump type/model	Variable plunger pump / 18			
	Main pump brand	Tai feng hydraulic			
	Max. flow rate of the main pump (L/min)	41.4			
	multiple unit valve	Tai Feng			
	Multiplex valve brand	rise rapidly			
	Rated setting pressure (Mpa)	18			
	Maximum set pressure (Mpa)	22			
	Walking hydraulic motor type	Built-in LTM02PA			
	Walking motor brand	Li kechuan			
	Motor displacement	354.9/627.9			
	Rotary hydraulic motor type	Send a			
	displacement	245			

Chapter 5: Common faults and solutions

5.1 Common Faults and Solutions of Excavator

Common faults	failure cause	countermeasure
The machine is weak and moves slowly	The overflow valve is blocked or overloose	Remove the cleaning unit or tighten the overflow valve
	Pump damage	Replace the hydraulic pump
	The oil pump air intake pipe is blocked	Clean up or replace the oil intake pipe
	engine room	Contact the manufacturer to repair the engine
The machine doesn't work	Pump damage	Replace the hydraulic pump
	The connector spline is damaged	Replace the coupling spline
	The fuselage tilted the hydraulic oil to one side	Add the hydraulic oil or set the machine to a level
The machine cant turn	The rotary motor gear falls off	Install the swing gear in place
	The rotary motor is damaged	Replace the rotating motor
The engine emits a faint blue smoke	Too much oil injection	Adjust the oil quantity according to the upper and lower limits of the oil table
	engine failure	Contact the manufacturer to repair the engine
The engine produced a faint	The air filter is blocked	Clean up or replace the air cleaner
	engine failure	Contact the manufacturer to repair the

black smoke		engine
The engine produced a white smoke	Mix the water with the diesel oil	Place the oil, and rinse once with the oil
The engine does not turn	The overflow valve is stuck	Remove the overflow valve, install gasoline, and add gasoline
	The overflow valve is set too tight	Adjust the loose overflow valve
The engine is not on fire	Battery voltage loss	Charge or charge with an external battery
	Diesel oil cannot be exported to the pipe, which contains air.	Pull off the diesel pipe on the engine, and exhaust air, and install or press the pump exhaust
	Diesel freeze	Select the appropriate diesel grade according to the local temperature
	engine failure	Contact the manufacturer to repair the engine
	The nozzle is blocked	Replace the nozzle
	Air filter plug	Replace the air filter element
	High-pressure oil pump damage	Replace the high-pressure oil pump
	Fuse fracture	Check and replace the fuse
	Electronic oil pump failure	Replace the electronic oil pump
	High-pressure oil pump damage	Replace the high-pressure oil pump
	Low temperature causes the engine oil to thicken	Change the engine oil
The engine throttle valve can be large or small	Diesel oil pipe folding, resulting in poor oil supply	Check the diesel oil pipes and adjust the direction to ensure a smooth oil supply
The throttle continued to	The engine throttle holder is locked	Release the engine throttle bracket

increase		
Cant increase the throttle	The throttle pull line is loose	Tighten the throttle valve cable line
The headlights are not on, and the code meter or monitor does not work	Line plugs fall off	Check whether the line plug is falling off or getting loose
	Parts are damaged	renewal part
The battery is not charged	The generator broken line	Check the engine wiring and reconnect it
	Fuse damage	Change the fuse
	The regulator is damaged	Replace the regulator
	Battery damage	Replace the battery
The crawler falls off	Mechanical tension relaxes	Support the machine, put the track into the tensioning wheel to start the machine, and adjust the mechanical tensioning device by using the rotating force of the driving wheel until the track rises.
Engine high temperature	Lack of antifreeze	Add antifreeze
	The cooling tank is blocked	Clean the water tank cooling hole
	Damage of thermostat	Replace the thermostat
	Plateau climate impact	Replace the high-pressure water tank cover
	engine failure	Contact the manufacturer to repair the engine
oil pressure warning unit	oil starvation	come on
	engine overheats	Check the coolant
	Sensor damage	Replace the sensor

	line fault	Check the line
The excavator oil cylinder does not move	Break the lever ball shaft or base	Replace the ball shaft or base
The operating lever cannot be returned or pushed back	The multiplex stem reset spring fixing screw is loose or detached	Reinstall the reset spring or tighten the reset spring retaining screws
	The core card is dead	Remove the spool to remove dirt on the surface with a proper amount of lubricating oil and reit

5.2 Clean the overflow valve (safety valve) and adjust the system pressure

As one of the core components of the hydraulic system, the overflow valve plays a decisive role in the system pressure. The overflow valve is too loose or stuck, which will cause the machine to be obviously weak, moving slowly, walking, turning, climbing, and no action of the crushing hammer. After adjustment, the excavator will operate very fast and the oil temperature will rise too fast.

5.3 Install a single track

First start the machine, drop the tracks of the fuselage side lift, unload the rubber tracks, and then put the track in the steering wheel (be careful not to mistake the track direction), pull the other end of the crawler, at the same time start the machine and the joystick drive wheel slowly to turn to, and use the driving force of the machine and pry lever auxiliary until the crawler completely loaded. Then, tighten the track by adjusting the mechanical tensioning device. Attention should be paid to safety in this series of operations, and improper operation may lead to serious safety accidents (such as involvement in the track,

crowbar swinging or flying out, etc.). If uncertain, contact the manufacturer for guidance.

5. 4 The engine will not catch fire when the diesel fuel runs out

Once the fuel runs out and cannot catch fire, first replenish the fuel, and then use the oil pump to inject a certain amount of fuel into the engine supply pipe.

Chapter 6: Maintenance and Maintenance

6.1 Notes for maintenance

Engine maintenance

As the main power system of the excavator, the engine needs to be maintained according to the Engine Operation Manual carried by the vehicle. Maintenance in strict accordance with the provisions of the engine operation manual can effectively improve the service life of the engine and reduce the occurrence of faults.

The main maintenance content mainly includes the following parts:

1. Engine run-in period care.
2. Oil replacement cycle, and supplement (the oil will be slowly consumed with the use of the machine, so it is necessary to regularly check the amount of oil, not refueling, and wait until the next replacement, the oil is insufficient and needs to supplement in time, otherwise it will cause serious consequences such as pulling cylinder, the engine damage caused by insufficient oil manufacturer will not warranty).
3. Replacement cycle of the oil filter and the diesel filter element.
4. Air filter element replacement cycle. When inspecting or maintaining the machine, mark the "Do not operate" warning message to prevent an unauthorized person starts the engine or touches the control handle. Before repair, turn off the engine, remove the key, and carry it around. Mark the "Do not operate" warning message in a prominent position such as the start switch or control lever.

Use the right tool

Do not use damaged or poor-performance tools or tools designed for other purposes. Use tools suitable for the relevant work.

Replace the safety-key components regularly

1. Ensure that the machine can be used safely for a long time, regular refueling, and check and maintenance. To improve safety, please replace the hose, safety belt, and other safety key components regularly.
2. "Safety critical components replaced regularly" are parts that undergo aging, wear, and functional degradation after reuse and whose performance changes over time. These characteristics of such parts can cause serious mechanical damage or personal injury, and it is difficult to judge the remaining service life only by visual inspection or operation feel.
3. If there is any damaged visual appearance, replace the "safety-critical replacement", even if the specified replacement interval is not reached.
4. Replace the fuel hose regularly. Fuel hoses wear over time, even in the absence of any wear symptoms.
5. Replace any wear symptoms, regardless of the replacement schedule.
6. Check and maintain the machine regularly. The following safety-critical components must be replaced regularly to improve safety. Damage to these parts can cause serious personal injury or fire.

List of key safety components

main body	Safety-critical components for regular replacement		replacement time
fuel system	fuel line		Every two years
	Filler on the fuel tank cover		
hydraulic pressure system	main pump	Hydraulic pipe (pump outlet)	Every two years
		Hydraulic pipe (pump suction port)	
		Hydraulic pipe (swing motor)	
		Hydraulic pipe (stroke motor)	
	working equipment	Hydraulic pipe (boom oil cylinder pipe)	
		Hydraulic pipe (rod-cylinder pipe)	
Hydraulic pipe (bucket oil cylinder pipe)			

		Hydraulic line (yaw cylinder line)	
		Hydraulic pipe (bulldozer cylinder pipe)	
		Hydraulic pipe (pilot valve)	
		Hydraulic pipe (auxiliary pipe)	

6.2 Fuel oil recommendation

Diesel oil shall meet the following standards and this table lists several current fuel specifications in the world.

Diesel specifications	area	Diesel specifications	area
GB252	China	BS2869-A1 or A2	Britain
ASTM D975 Number: 1-D, S15	America Canada	ISO 8217DMX	International
biodiesel Biodiesel mixture B5 ASTM D6751, D7467			
EN590:96	EU	Grade JIS K2204 2	Japan
Biodiesel mixture (fuel sulfur content not exceeding 10ppm)			

1. To maintain the engine performance and service life, always use clean, high-quality fuel. To prevent freezing in cold weather, choose the diesel fuel that is still applicable when the actual temperature is at least 2°C lower than the outdoor minimum expected temperature.
2. Please use diesel fuel with a cetane value of 45 or above. When used in high cold or high altitude areas, fuel with high cetane value is needed.
3. Please use the fuel with less than 0.05~0.10 15% (ultra-low sulfur fuel should be used

in the United States or Canada), which may cause sulfuric acid corrosion in the engine cylinder.

4. The use of kerosene is prohibited. Do not mix kerosene, used engine lubricants, or residual fuel with diesel fuel.

5. Poor quality fuel can reduce engine performance or cause engine damage. Fuel oil additives are not recommended. Some fuel additives can reduce the engine performance.

6. Metal content, such as zinc, sodium, silicon, and aluminum, must be limited to one per million mass (1mass ppm) or less.

7. Use standard-compliant biodiesel, for substandard machines or deteriorated biodiesel.

6.3 Description of the machine lubrication parts

Lubrication area diagram

Details of the 23 refueling ports for model R18-4 are as below:

Butter mouth position	quantity
(1) The connection between the bucket and the rod, the bucket and the bucket	Two
(2) the connection of connecting rod, bucket rod, and digging bucket oil cylinder, the connection of the rocker and bucket rod	Two
(3) The connection of the bucket rod oil cylinder with the boom and the bucket rod	Two
(4) Connect the boom with the bucket rod and connect the boom cylinder with the boom	Three
(5) The boom support is connected to the upper plate, and the boom support is connected to the boom	Three
(6) The butter tightening of the guide wheel tightening device	Two
(7) The connection between the bulldozer and the main body of the lower plate	Two
(8) The connection between the bulldozer cylinder and the lower plate, and between the bulldozer cylinder and the bulldozer shovel	Two
(9) Gear lubrication of the rotary motor and inner ball lubrication and	Three

deflection cylinder of the swing support	
(10) The connection between the telescopic oil cylinder and the left and right walking bracket	Two

Total position diagram of 23 refueling ports for the R18-4 model:

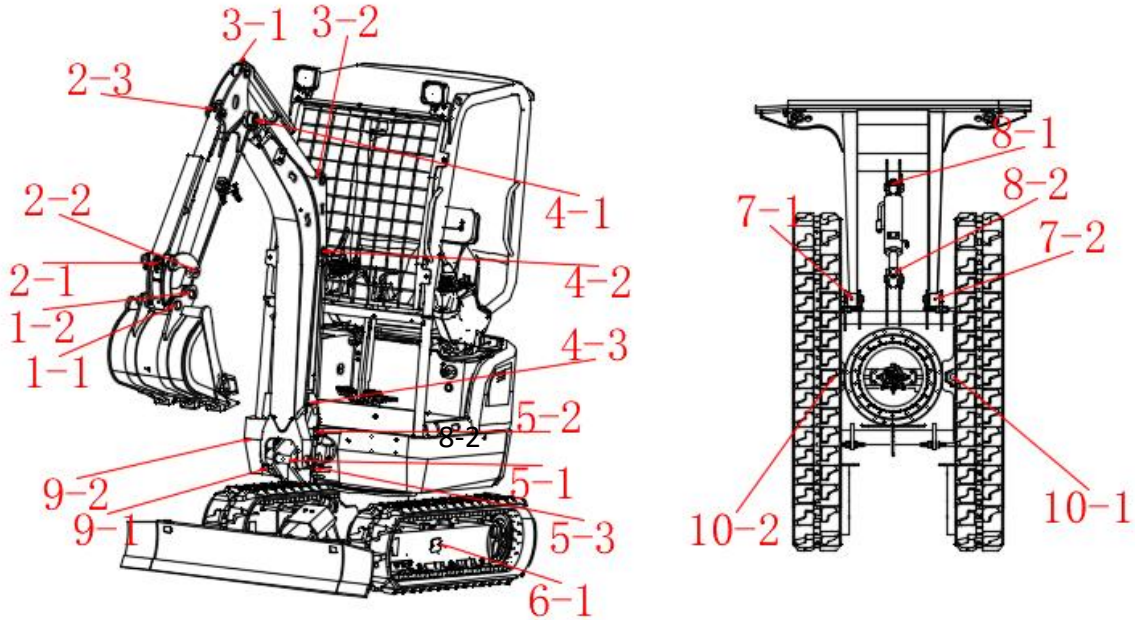

The user must add enough butter to the above refueling point every 48 hours.※

6.4 Maintenance directory

Excavator maintenance catalog table:

Excavator Repair Directory						
Filter name	first		Convention		mod el	remarks
	period	Maintenance method	period	Maintenance method		
oil filter	50 Hours	renewal	200 Hours	renewal	/	
Empty filter	50 Hours	put in order	200 Hours	renewal	/	For poor working conditions, the cleaning and replacement cycle will be shortened (air blowing, not washing)
Diesel filter	50 Hours	renewal	200 Hours	renewal	/	
Empty filter	500 Hours	renewal	1000 Hours	renewal	/	

Hydraulic oil suction filter	300 Hours	renewal	600 Hours	renewal	/	
Hydraulic oil return filter	300 Hours	renewal	300 Hours	renewal	/	

Oil product maintenance schedule:

name	first		convention l		model	remarks
	period	Maintenance method	period	Maintenance method		
engine oil	50 Hours	renewal	200 Hours	renewal	CD 15W-40 (PC10 model)	Choose the appropriate oil model according to the local temperature
antifreeze	q.d	check up / replenish	annu m	renewal	CF-4 15W-40 (other model)	Not mixed with water (use appropriate antifreeze model according to local temperature)
diesel oil	q.d	check up / replenish	/	/	/	Use diesel fuel from regular gas stations. Poor diesel will cause damage to fuel pumps, fuel injectors, and other components (select appropriate diesel grade according to the local temperature)
hydraulic fluid	300 Hours	renewal	600 Hours	renewal	46#Anti-wear hydraulic oil	
Walking motor gear oil	50 Hours	renewal	500 Hours	renewal	L-CKD 220	
butter	The new machine	add	8 Hours	add	/	
Water tank radiator	50 Hours	put in order	50 Hours	put in order	/	Air-blowing or high-pressure water flushing
Hydraulic	50 Hours	put in order	50	put in order	/	Air-blowing or high-pressure

oil radiator			Hours			water flushing
--------------	--	--	-------	--	--	----------------

Inspection list of important components:

Important check parts	period	Maintenance method	period	Maintenance method	remarks
Ropin' the for rotary screw	30 Hours	check up	30 Hours	check up	If loose, tighten immediately
Rowing support fixing screw	30 Hours	check up	30 Hours	check up	If loose, tighten immediately
Engine retaining screws	30 Hours	check up	30 Hours	check up	If loose, tighten immediately
Track tensioning device	Before work	check up	Before work	check up	If the tracks are loose, add the butter immediately

pay attention to:

1. Please follow the maintenance cycle and conduct regular maintenance. For equipment failure caused by delayed or delayed maintenance, the manufacturer will not provide three guarantees.
2. Please use genuine parts for the repair. Poor parts or oil may cause rapid wear or severe failure of equipment.
3. Irregular inspection of rotary motor fixing screw, rotary support fixing screw, and engine fixing screw, may cause rotary motor gear tooth out, flange damage, rotary support tooth out, engine wind ring damage, water tank leakage, and other accidents. The manufacturer does not provide three guarantees.

6. 5 Replace the engine oil

Precautions for oil change

1. Oil change must be performed in heat engine condition.
2. Do not start during the oil change process and before the new oil is added.
3. The oil injection amount is close to the upper limit of the oil ruler but does not exceed the upper limit.
4. The oil filter element must be replaced during the oil change.

R18-4:

As shown in the figure below, screw out the oil screw, release the oil, and catch it with a container. Unscrew the refueling cover, add new oil to the engine, and tighten the refueling cover after refueling.

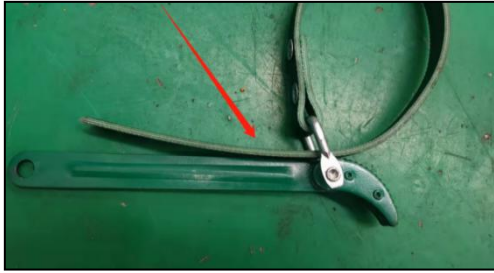

6. 6 Method of replacing the filter element

As shown in the figure below, when the JBT engine replaces the filter element, open the rear shield forward first, and all the filter elements can be seen after opening. Remove the cover shell on the filter element with a wrench, and then remove the filter element for replacement.

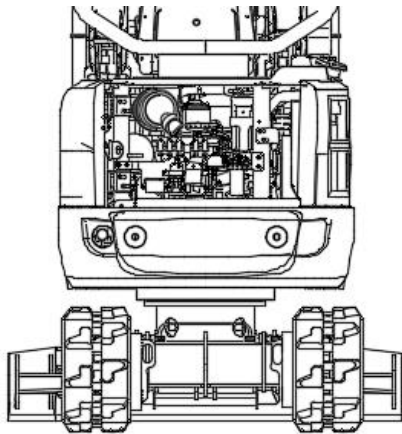

The hydraulic fuel tank has a built-in filter element. Remove the left cover before replacing the filter element. At this time, the hydraulic oil tank and the pipeline leak outside. Use the wrench to remove the oil pipe and screws at the return line, open the oil tank cover, and take out the old filter element. Install the new filter element, connect it back to the oil pipe, and check whether the pipe is tightened and the filter element is replaced.

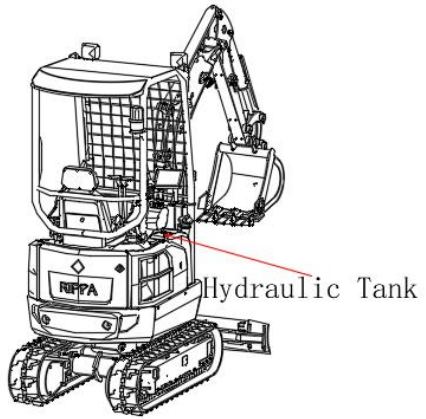

The EC qualification declaration

editio princeps

manufacturer:

Name: Shandong Libao Machinery Group Co., LTD
Address: No.6, Industrial Park, No.2166, Chongwen Avenue, High-tech Zone, Jining City, Shandong Province

Authorized representative:

23566, Lubecwa, De West, Germany

Authorized to keep the technical documents on behalf of the above manufacturer

We hereby declare that the following machines are described below:

Machine description

Product name: HYDRAULIC CRAWLER EXCAVATOR
Model / Category: R18-4
Serial number:
Date of manufacture:

Voucher:

Mechanical instructions	2006/42/EC EN 474-1:2022; EN 474-5:2022
ELECTROMAGNETIC COMPATIBILITY INSTRUCTIONS	2014/30/EU EN ISO 13766-1:2018; EN ISO 13766-2:2018

And the following other directives and the corresponding national regulations:

Noise instructions	2000/14/EC & 2005/88/EC, DLGS 262/02
--------------------	--------------------------------------

Equipment as defined in Annex I, Item 20 of the Noise Directive.

Conformity assessment procedure followed: 2000 / 14 / EC

Announcement Body Annex viii: European Certification Organization S. P. A NB 0714, via MENGOLINA 33, FAENZA (RA), Italy

Technical Document holder: Manufacturer

Measuring noise grade: 92 dB (A)

Guaranteed noise level: 93 dB (A)

Signed on behalf of Shandong Lipai Machinery Group Co., LTD.

Seal & Signature:

Name:

Post:

Address:

Date:

List of accessories and spare parts

Annex list

Annex list

1. Foot pads

2. Accessories

Accessories name	quantity	type
		R18-4
14 Inch Toolbox	1	○
Right Angle sleeve	1	○
grease gun	1	○
shifting spanner	1	○
hold-all	1	○
Filter filter element wrench	1	○
inner hexagon spanner	Group 1	○

3. Random files

- ①. One operation and maintenance manual
- ②. Three packages of service vouchers: 1 copy
- ③. One qualification certificate
- ④. Engine manual: 1 copy